

FORKLIFT

ME50-45T



OPERATING WEIGHT

Standard configuration,
fuel tank full and 80 kg operator

8.165 kg

ENGINE

Manufacture	XINCHAI
Model	10582140
Net power	114 HP
Maximum net torque	450 N.M
Engine capacity	7,19 ℓ

GENERAL CHARACTERISTICS

Lifting capacity	4.479,36 mm
Loading capacity	5.035 kg
Tower inclination angle	6/12 degrees
Maximum climbing angle (with load)	38%
Overhead guard height	2.438 mm
Wheeled (front/rear)	8.25-15-14PR / 8.25-15-14 PR
Distance from load center	497.84 mm
Lifting speed	449.6 mm/s
Travel speed	29 km/h

DIMENSIONS

A – Load height	4.479,36 mm
B – Wheelbase	2.286 mm
C – Ground clearance	229 mm
D – Front axle distance	1.463 mm
E – Rear axle distance	1.707 mm
F – Length	3.353 mm
G – High	2.438 mm
H – Ancho	1.219 mm

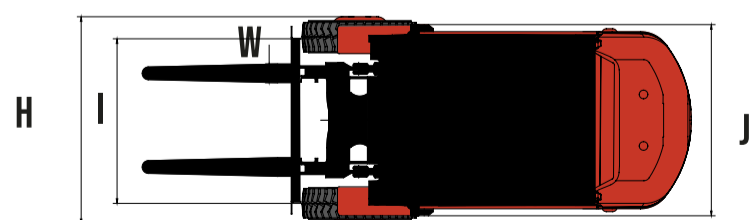
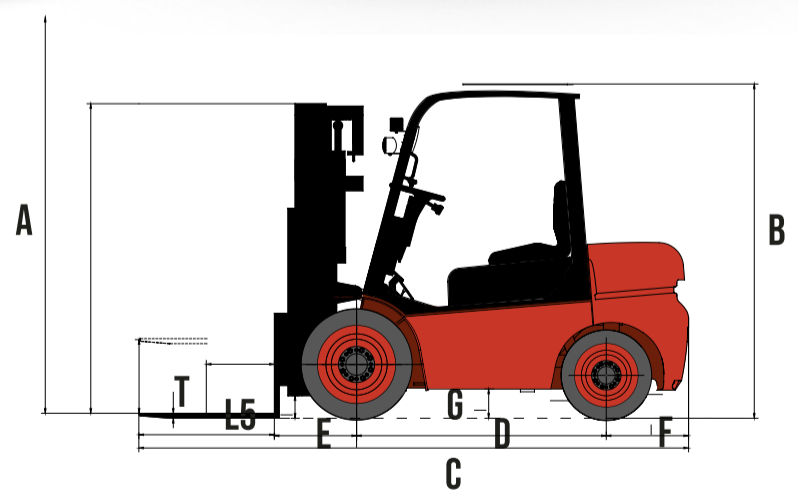

MICHIGAN

LOGISTICS LINE

+1 954 697 5718

**GLOBAL STRENGTH
AND TRADITION**

MICHIGAN reserves the right to implement design improvements and changes in specifications at any time, without incurring any obligation to install them on units previously sold. The specifications, descriptions, and illustrative materials contained herein accurately reflect the data known at the time of publication, but may vary by region and are subject to change without prior notice. Illustrations may include optional equipment and accessories and may not include all standard equipment.