

FORKLIFT

ME60-45T



OPERATING WEIGHT

Standard configuration,
fuel tank full and 80 kg operator

8.890 kg

ENGINE

Manufacture	XINCHAI
Model	10582160
Net power	114 HP
Maximum net torque	450 N.M
Engine capacity	7,19 l

GENERAL CHARACTERISTICS

Lifting capacity	4.479,36 mm
Loading capacity	5.987 kg
Tower inclination angle	6/12 degrees
Maximum climbing angle (with load)	35%
Overhead guard height	2.256 mm
Wheeled (front/rear)	8.25-15-14PR / 8.25-15-14 PR
Distance from load center	599.4 mm
Lifting speed	508 mm/s
Travel speed	29 km/h

DIMENSIONS

A – Load height	4.479,36 mm
B – Wheelbase	2.286 m
C – Front axle distance	1.463 mm
D – Rear axle distance	1.707 mm
E – Length/Length without nails	3.566 / 1.219 mm
F – High	2.256 mm

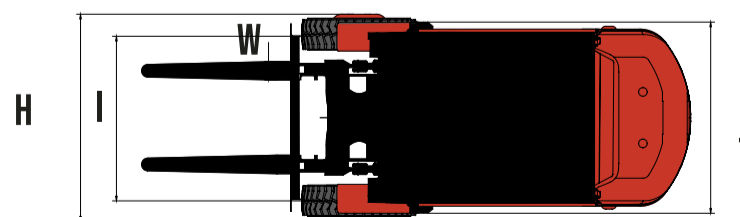
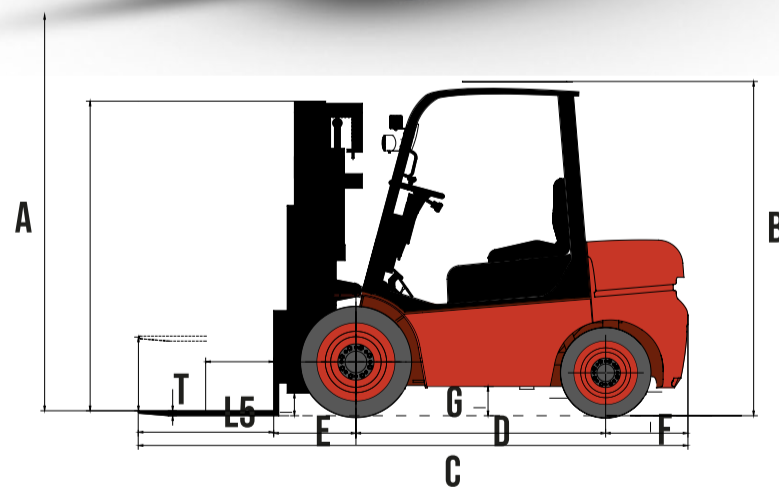

MICHIGAN

LOGISTICS LINE

**GLOBAL STRENGTH
AND TRADITION**

+1 954 697 5718

MICHIGAN reserves the right to implement design improvements and changes in specifications at any time, without incurring any obligation to install them on units previously sold. The specifications, descriptions, and illustrative materials contained herein accurately reflect the data known at the time of publication, but may vary by region and are subject to change without prior notice. Illustrations may include optional equipment and accessories and may not include all standard equipment.